



Full Featured Battery Operated  
Backlight LCD Indicator



Rugged Self-Contained  
Cast Iron Platform



Locking Swivel Wheels

# CWP Series

## Portable Digital Utility Scale

- Complete with full function battery operated LCD Display
- Ergonomic design insures portability & versatility
- Rugged cast iron industrial platform
- Lockable weigh platform
- Industrial locking casters
- Folding handle for storage ease



CWP Series ▼

**CAS**

[www.cas-usa.com](http://www.cas-usa.com)

# CWP | Portable Digital Utility Scale

## CWP SPECIFICATIONS

Model		CWP-150	CWP-300
Capacity & Resolution	lb	150 x 0.05 lbs	300 x 0.1 lbs
	kg	60 x 0.02 kg	150 x 0.05 kg
Operating Temperature		-10°C ~ 40°C / 14°F ~ 104°F	
Dimensions	Inches	37.8 (H) x 27.6 (L) x 15.7 (W)	
	mm	960 (H) x 701 (L) x 399 (W)	
Product Weight		64 lbs	



## CI-201A Specifications

Keys	0-9 Full Keyboard, 2 Function Keys, Clear, Enter, Power
Display Designators	ZERO, TARE, GROSS, NET, STABLE, UNIT
Weigh Modes	Weight, Count, Percent, Sub-Total / Total
Tare	Keyboard Tare
Display Digit	6 Digits - Character Height: 24 mm / 1 in
Display Type	LCD with Adjustable Backlight
Enclosure	IP 65 Rated Hardened Plastic Enclosure
Power	DC 12V Adapter / 1.25A
	6V Rechargeable Battery
Battery Life	Approximately 25 Hours
Battery Charging Time	Approximately 12 Hours

## DIMENSIONS

Unit: inch/mm

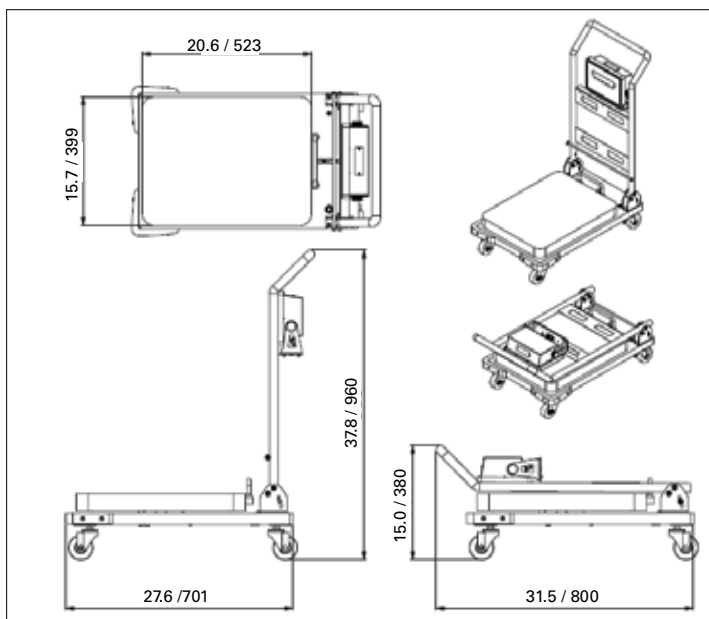

99 Murray Hill Parkway Unit A  
 East Rutherford, NJ 07073  
 TEL: (201) 933-9002  
 FAX: (201) 933-9025  
<http://www.cas-usa.com>

Specifications are subject to change for improvement without prior notice.